

LED Obstruction light Single Assembly

Made in THAILAND

Model : 48W5

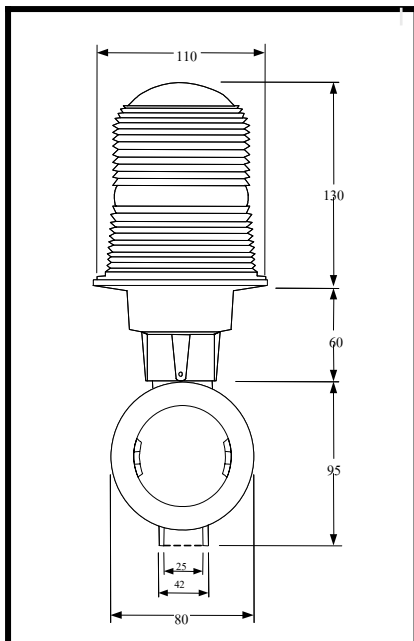

Compliance with following

Specification AC # 1505345-43E

ICAO (ANNEX 14, THIRD EDITION-

JULY 1999 Chapter 6)

Obstruction light is the first certified
LED based L-810 obstruction light.

Designed for steady burning. This fixture
Is used to mark any obstacle that may
present hazards to aircraft navigation



Features

- LED Red lamp , Chip technology –AllnGap / Gap and Standard 5 mm (T-1 3/4") Water clear package
- More than 70,000 Hours life average at normal usage.
- Low power consumption 5 W (±1 W) at DC 48 V.
- Transient protection circuit over to 6KV 3 KA standard
- Properties structure to be Earth grounding provisions provided
- Unique optically designed lens to enhance LED operation and provide 360°visibility at 15 cd typical
- Weather/corrosion resistant lamp assembly and housing IP 65
- Self-contained winding compartment eliminates additional boxes
- Single fixture
- Threaded 3/4" bottom hub for mounting

* Obstruction light LED 48VDC double type Model: 48W5D

Weight:

SINGLE OB.LIGHT 4.5 lbs, 2.0 kg



B.S.E. ELECTRONIC CO., LTD. (THAILAND)

Tel. (662)803-6303-4, (662)803-7637 Fax. (662)803-7636

Website : www.bseelectronic.com E-Mail :info@bseelectronic.com