

LED Obstruction light Single Assembly

Made in THAILAND

Model : 220W14



Legend (C-Planes)

- 0°
- 45°
- 90°
- 135°
- 180°
- 225°
- 270°
- 315°
- 360°

Luminous Intensity (cd / 1000 lm)

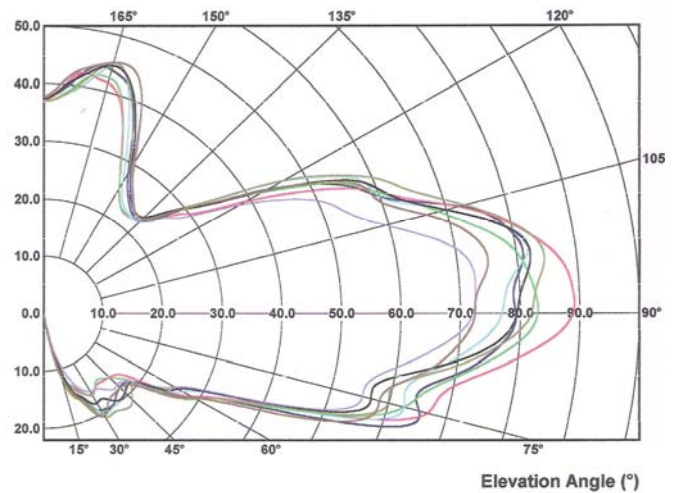

Compliance with following Specification

AC # 1505345-43E

ICAO(ANNEX 14,THIRD EDITION-JULY

1999) MIL-C-25050

Features

- LED Red lamp , Chip technology –AllnGap / Gap and Standard 5 mm (T-1 3/4") Water clear package
- More than 70,000 Hours life average at normal usage.
- Low power consumption 14 W (± 1 W) at AC 180-250 V.
- Transient protection circuit over to 6KV 3 KA standard
- Properties structure to be Earth grounding provisions provided
- Unique optically designed lens to enhance LED operation and provide 360° visibility at 25 cd. typical
- Weather/corrosion resistant lamp assembly and housing (IP 65)
- Self-contained winding compartment eliminates additional boxes
- Single fixture
- Threaded 3/4" bottom hub for mounting

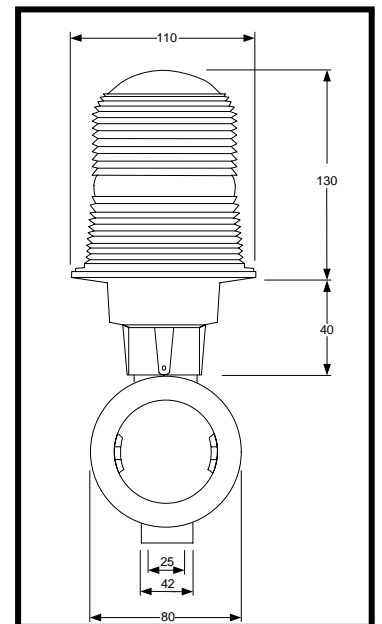

Weight:

SINGLE OB.LIGHT 4.5 lbs, 2.0 kg



B.S.E. ELECTRONIC CO., LTD. (THAILAND)

Tel. (662)803-6303-4, (662)803-7637 Fax. (662)803-7636

Website : www.bseelectronic.com E-Mail : info@bseelectronic.com