

Applications: OB.Light red steady-burning obstruction lights are used to mark tall structures that present hazards to air navigation. During the night, these lights warn pilots to stay clear of the obstruction when installed in accordance with FAA AC 70/7460-1 and applicable FCC and ICAO rules and recommendations. Together with flashing FAA L-864 red beacons and BSE controllers, BSE OB.Light contribute to integrated lighting system. Applied individually, single and double BSE OB.Light mount directly to conduit risers and may be combined with a BSE controllers universal transfer & alarm relay for lamp backup and remote lamp failure alarm indication. Usually, one photoelectric controller is sufficient to provide automatic lighting activation at dusk in accordance with FAA specifications. All BSE OB.Light include lens tethers.

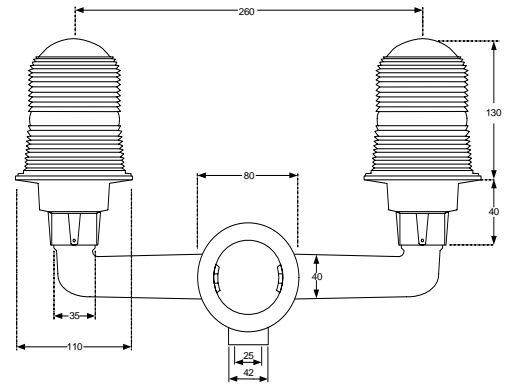
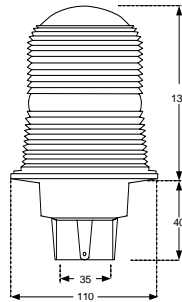
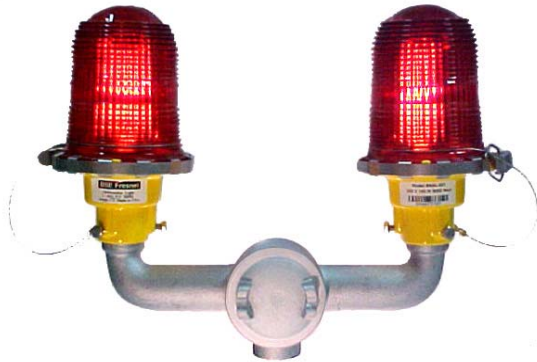

Features:

- Red fresnel glass globes for 360° visibility
- Operates on 120 or 220-240 volts and 60 or 50Hz frequency power supply when used with proper voltage lamp
- Threaded hub (1 Inch) for mounting
- Pre-wired leads
- Cast aluminum housing with yellow finish
- Globes with tether & clamp band
- Accepts traffic signal lamps with USA medium screw base and European E27 base
- O-Ring globe seal
- Lamp Life 4000 hours at 120 Volts or 8,000 hours for 220-240V and more than 70,000 hours for LED lamp application.

Models:

- BF1220100** SINGLE OB.LIGHT 220 V 100 W
- BF1220060** SINGLE OB.LIGHT 220 V 60 W
- BF1120116** SINGLE OB.LIGHT 120 V 116 W
- BF1220R5E27** SINGLE LED RED COLOR lamp 220 V 5W E27
- BF2220100** DOUBLE OB.LIGHT 220 V 100 W
- BF2220060** DOUBLE OB.LIGHT 220 V 60 W
- BF2120116** DOUBLE OB.LIGHT 120 V 116 W
- BF2220R5E27** DOUBLE LED RED COLOR lamp 220V 5W E27



LED RED lamp 5W E27

Incandescent Lamp E27

Weight:

SINGLE OB.LIGHT 4.5 lbs, 2.0 kg
 DOUBLE OB.LIGHT 10 lbs, 4.5 kg